



Expect luxury & innovation with the Lux-V series!

Built with the latest full DC inverter technology and fast and efficient automatic defrosting, the Lux-V Series can handle any heating or cooling requirement - all year round.

Its stylish ABS and metal cabinet can withstand harsh weather conditions, while the vertical air discharge provides efficient airflow and space saving installation options.

The Lux V Series is packed with premium features, like its intelligent LCD touch screen controller, smart operating modes and wi-fi control.

- Stylish ABS & galvanised cabinet: durable against harsh weather conditions.
- Intelligent Controller: 4 smart operating modes
- C.O.P of up to 14.2
- Vertical air discharge
- Latest DC full inverter technology including compressor, fans & control
- Wi-Fi Control: control your pool heater anywhere, anytime.

Performance		Heating	Heating	Cooling
		Winter	Summer	Summer
Ambient Air Temp.	°C	15	27	35
Entering Water Temp.	°C	26	26	30
Heating/Cooling Capacity	kW	2.4~10.0	3.5~13.5	5.53
Consumed Power	kW	0.32~2.13	0.26~2.08	1.5
C.O.P.		7.5~4.7	13.5~6.5	3.65
Power Supply		220-240/1/50		
Air Flow	m ³ /h	2500-3500		
Compressor	Type	Rotary	Panasonic	1
	Brand			
Heat Exchanger	Material	Titanium	Tube in shell	Spiral (Twisted)
	Type	Yes		
Fan	No.	1	250 W	Speed
	Power Input	500-750 RPM		Direction
Operating Air Temp.	°C	-15 to 43		
Max. Rated Input Power	kW	3.09		
*Running Current at 100%	A	9.56		
Refrigerant		R32		
Casing Type		ABS front/galvanized steel rear		
Connection Type		15amp		
Defrost		Auto Defrost (Reverse Cycle)		
Moisture Resistance		IPX4		
Noise (1M)	dB(A)	41-53		
Noise (10M)		13-25		
Water Connection	mm	40		
Water Flow Volume	L/min	108		
Water Pressure Drop (max)	kPa	6.8		
Net Weight	kg	48		
Net Dimensions (LxWxH)	mm	650 x 626 x 943.5		

*Running current does not include load of circulation pump.

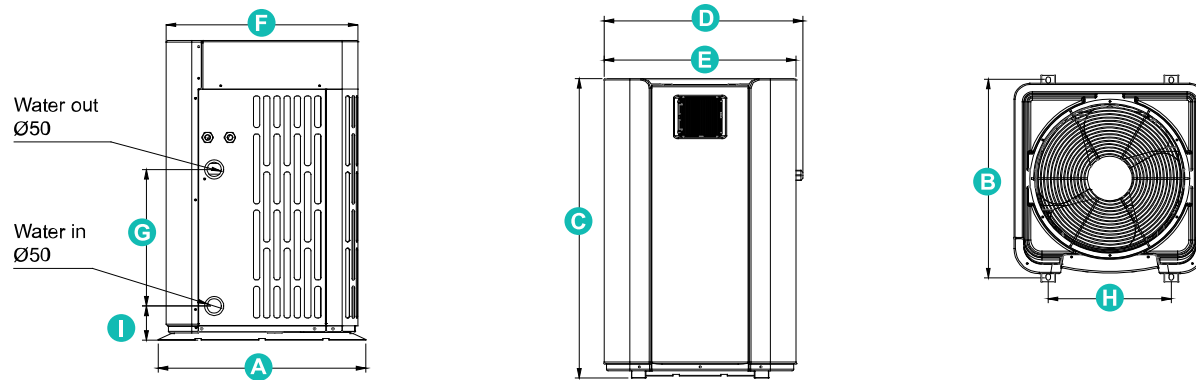

Unit: mm	A (L)	B (W)	C (H)	D	E	F	G	H	I
	650	626	943.5	622	600	600	430	385	107.5

PERFORMANCE CURVES

